

Terminator™ ZE-B-WP Beacon

LED End of Circuit
Light Kit - Wall Mount

INSTALLATION PROCEDURES



Terminator™ ZE-B-WP Beacon

The following installation procedures are suggested guidelines for the installation of the Terminator ZE-B-WP Beacon. For translations other than English and local language translation provided here, please contact Thermon. The English language installation procedure shall govern.

Kit Contents



Item	Quantity	Description
1	1	Expediter Assembly Grommet Compressor Grommet Wall Mount Support Base with O-Ring
2	1	Light Module Cover
3	1	LED Light Module
4	1	Wall Mount Bracket
5	3	M5 Screws
6	3	Lock Washers
7	1	Banding

The Specific Conditions of Use are:

1. The kits are intended for use with BSX, HTSX, KSX, RSX, USX, VSX-HT, HPT, and FP heat tracing cables.
2. The equipment can only be used in areas of low impact risk.
3. Avoid electrostatic charge. Clean only with a damp cloth.
4. The maximum operating voltage rating is limited to 275 VAC when wiring is done using the terminal block option.
5. Minimum installation Temperature for terminators that use the Weidmuller terminals is -50°C.

Certifications/Approvals

IP66 -60°C ≤ Ta ≤ +45°C, T6, T85°C
 -60°C ≤ Ta ≤ +55°C, T5, T85°C

International Electrotechnical Commission
 IEC Certification Scheme for Explosive Atmospheres

IECEx FMG 18.0026X Ex eb mb IIC T6...T5, Gb
 Ex tb IIIC T85°C, Db

0344 II 2 GD Ex eb mb IIC T6...T5, Gb
 Ex tb IIIC T85°C, Db
 FM 18ATEX0065X

Terminator has additional hazardous area approvals including:

- GGTN • Kazakhstan

Dimensions



Tools Required

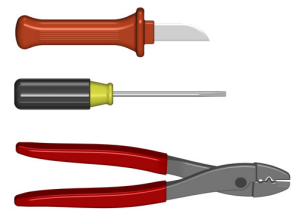

Note: Crimp Tool - Ideal 30-429 or factory approved alternate.

Installation Precautions

- To minimize the potential for arcing and fire caused by product damage or improper installation use ground-fault protection.
- Installation must comply with Thermon requirements and be installed in accordance with the applicable national and local codes.
- Component approvals and performance ratings are based on the use of Thermon specified parts only.
- De-energize all power sources before opening enclosure.
- Keep ends of heating cable and kit components dry before and during installation.
- Individuals installing these products are responsible for complying with all applicable safety and health guidelines. Proper personal protective equipment, or PPE, should be utilized during installation. Contact Thermon if you have any additional questions.

Receiving, Storing and Handling

1. Inspect materials for damage incurred during shipping.
2. Report damages to the carrier for settlement.
3. Identify parts against the packing list to ensure the proper type and quantity has been received.
4. Store in a dry location.

Order Separately

SCTK Connection Termination Kits (per cable)

SCTK-1	for BSX, RSX, VSX-HT
SCTK-2	for KSX, HTSX, USX
SCTK-3	for FP, HPT

Order Separately

SCTK Terminal Block Connection Kits (per cable)

SCTK-1TB	for BSX, RSX, VSX-HT
SCTK-2TB	for KSX, HTSX, USX
SCTK-3TB	for FP, HPT

INSTALLATION PROCEDURES

Order Separately

IEK Insulation Entry Kit (per cable)

IEK-20	for RSX, VSX-HT
IEK-19	for BSX
IEK-14	for KSX, HTSX, USX
IEK-18	for HPT

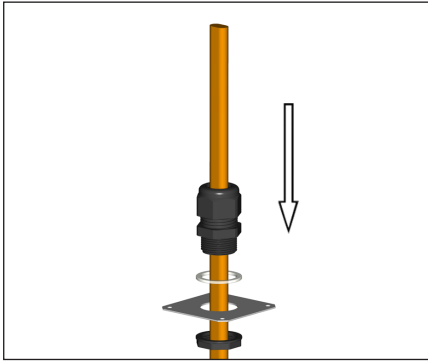
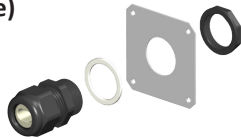

1. Slide appropriate IEK insulation entry kit components onto cable.

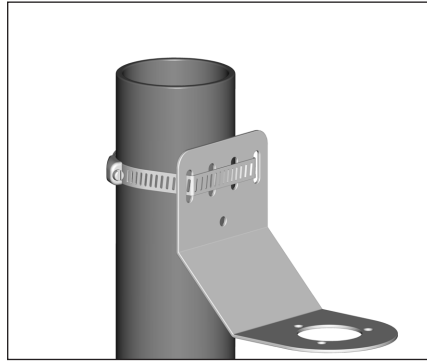

2a. Mounting Method 1: Secure wall mount bracket to mounting surface using banding provided with kits.

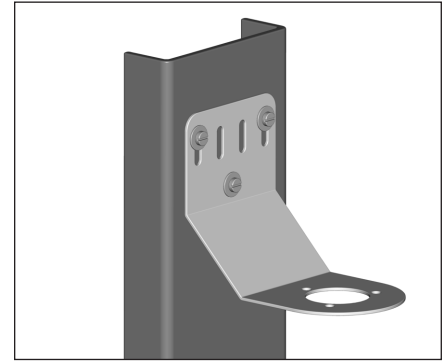

2b. Mounting Method 2: Secure wall mount bracket to mounting surface using customer supplied screws, flat washers, and nuts.

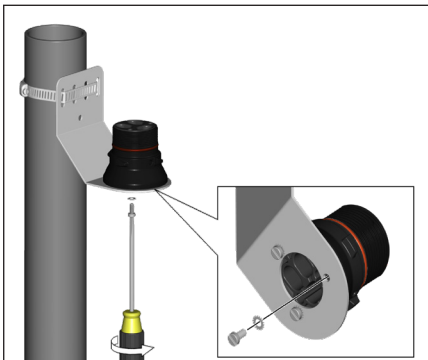

3. Mount expediter to bracket using M5 x 8 mm screws and M5 lock washers.

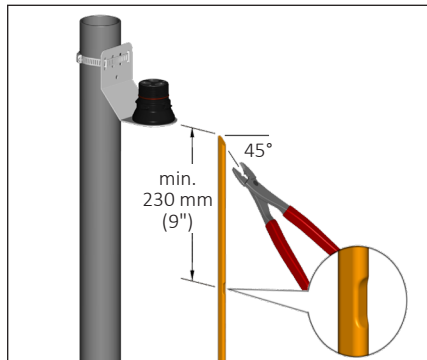

4. Locate bus connection (HPT and FP only) as shown. Cut end of cable at angle to aid in piercing grommet. Leave additional cable for expansion as needed.

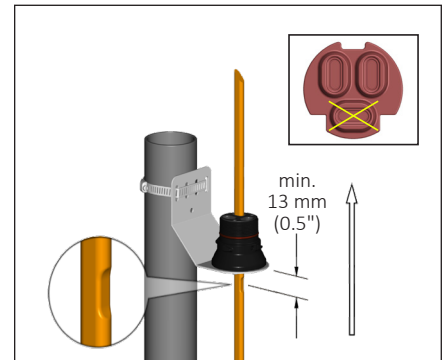

5. Insert cable into expediter. Make sure bus connection (HPT and FP only) remains outside of expediter.

Note: for HPT and FP cable, exchange grommet in Terminator with GRW provided in SCTK-3(TB).

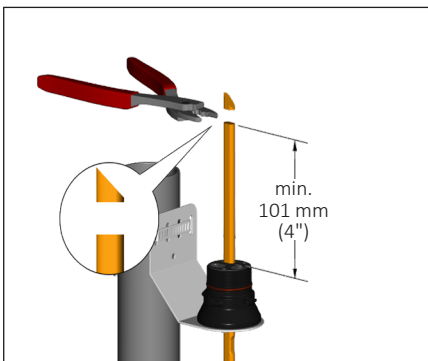

6. Cut off end of cable.

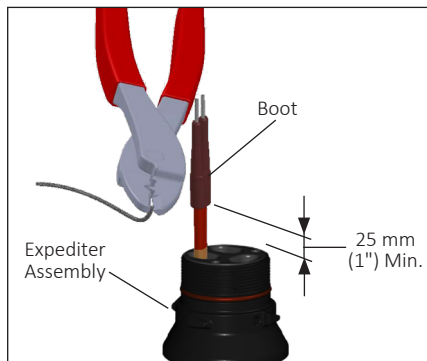

7. Terminate cable with appropriate SCTK termination kit. Refer to SCTK installation instructions. Push excess cable back through expediter. Remove braid pigtail. Tape cable expansion loop to pipe.

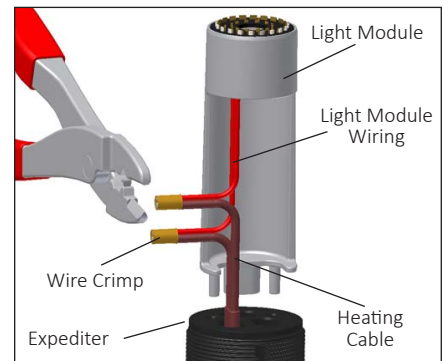

8. When using crimps: Connect heating cable to light module wires using small crimps. See steps 9–11.

When using terminal block: See steps 12–14. See wiring schematic for connection details.

Terminator™ ZE-B-WP Beacon

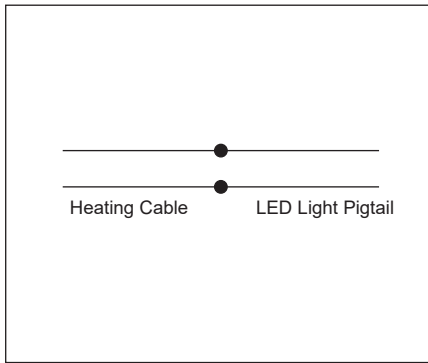

Wiring Details for LED Light

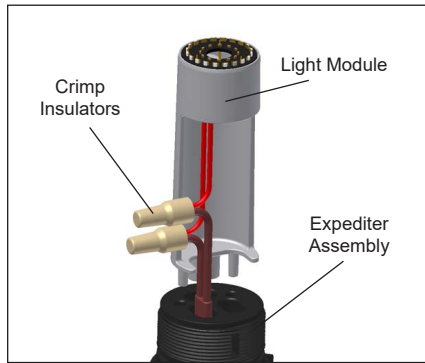

9. Snap on crimp insulators.

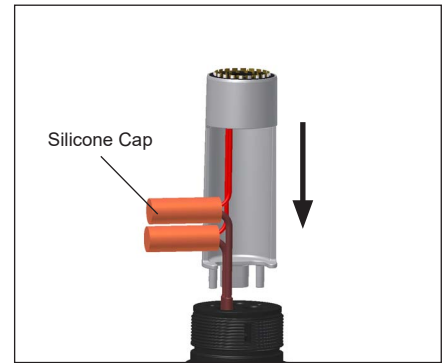

10. Slide silicone caps over crimp insulators. Install Light Module to Expediter.

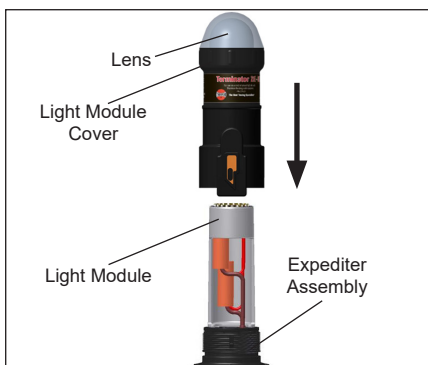

11. Arrange crimped leads to fit inside light module base. Slide the light module cover over light module.

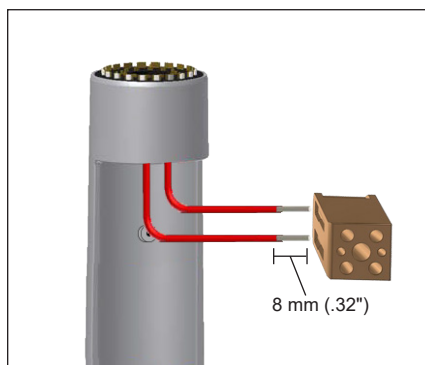

12. When using SCK-TB Connection Kit, first trim exposed bus wires of the LED pigtail to 8 mm (.32"), then connect to the terminal block.

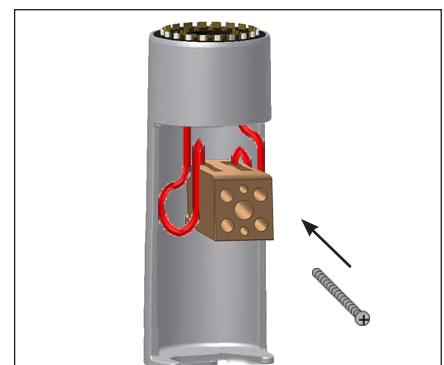

13. Use the terminal block mounting screw to mount terminal block to the LED light module. Bend each pigtail lead around the sides of the terminal block.

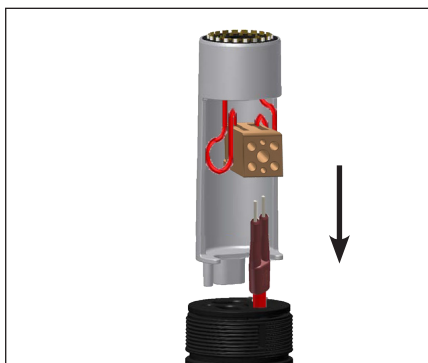

14. Connect the bus wires of the trace heater to the terminal block.



15. Engage threads. Rotate light module cover clockwise and tighten cap securely. Make sure latch mechanism is in the locked position.

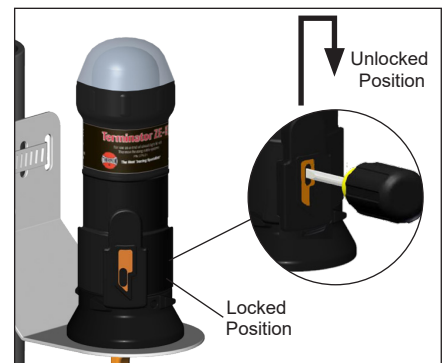

16. To remove cap, de-energize circuit, lift latch mechanism, and unscrew cap.



European Headquarters: Boezemweg 25 · PO Box 205 · 2640 AE Pijnacker · The Netherlands · Phone: +31 (0) 15-36 15 370
Corporate Headquarters: 100 Thermon Dr · PO Box 609 San Marcos, TX 78667-0609 · Phone: 512-396-5801 · 1-800-820-4328

For the Thermon office nearest you visit us at . . . www.thermon.com

Form PN50887U-0323

© Thermon, Inc. · Printed in U.S.A. · Information subject to change.